

**KMS.UARA.3000.1/1.7.SAEC SPLIT SHAFT PTO MOUNTING  
AND USER MANUAL**

## **Table of Contents:**

<b>Safety Information.....</b>	<b>3</b>
<b>Instructions for Operation in Cold Weather .....</b>	<b>3</b>
<b>Split Shaft PTO Features.....</b>	<b>4</b>
<i>Technical Data</i>	
<b>Split Shaft PTO Mounting.....</b>	<b>5</b>
<b>Engage and Disengage.....</b>	<b>6</b>
<b>Servicing and Maintenance.....</b>	<b>7</b>
<i>Adding Oil</i>	
<i>Recommended Lubricants</i>	
<i>Oil Level Inspection</i>	
<i>Oil Change</i>	
<i>Oil Leakage Detection</i>	
<b>Periodic Maintenance.....</b>	<b>9</b>
<b>Precautions for Emergency Situations.....</b>	<b>10</b>
<b>Technical Drawings.....</b>	<b>10</b>
<b>Warranty Terms.....</b>	<b>11</b>
<i>Situations Which Terminate Warranty Obligations</i>	

---

 **The pictures used in this manual are for demonstration purposes and may not be identical to the actual purchased products.**

## **Safety Information**

The following information is for your safety. Make sure to read and understand them before attempting to use the equipment.

### **Overall Safety**

- ✓ Carefully read the user manual provided and take notice of the instructions indicated.
- ✓ The important sections for operator safety and a prolonged product life are marked with symbols. Take notice of such symbols.
- ✓ Make sure to check if the instructions you follow and the tools you use are intended for the work you are engaging in.
- ✓ Never work alone when doing repair or maintenance works under the vehicle.
- ✓ Ensure to mount the parts properly.
- ✓ Never use worn or damaged parts.
- ✓ Do not attempt any modification on the split shaft PTO or any other drive components of the vehicle.

## **Instructions for Operation in Cold Weather**

In extremely cold weather (0°C and below), the disengaged PTO may momentarily transmit high torque and cause rotational movement of the output shaft. This movement can cause personal injury or damage to the PTO.

For prevention of injuries and damage to the gearbox;

- ✓ Check the drive components of the vehicle.
  - ✓ Do not attempt to use drive components without warming up the vehicle.
-

## Split Shaft PTO Features

**KMS.UARA.3000.1/1.7.SAEC** is a gearbox with mechanical shifting system particularly designed for combined cleaning and washing vehicles.

The gearbox is powered by the propeller shaft from the transmission. A single pneumatic piston is employed to disengage the differential output and engage the top output shaft. The vehicle main shaft must come to a full halt before engaging or disengaging the PTO outputs. Where it is desired to engage and disengage the installed equipment (pump), a clutch system must be installed between the PTO output and the equipment. This will eliminate the requirement to stop the rotation of the main drive shaft.

### Technical Data

#### Main Input – Output

Maximum Continuous Torque	22127 lbf-ft
Maximum Instant Torque	26552 lbf-ft
Maximum Speed	2500 – 3300 rpm

#### Pump Output

Pump Direction	Right Rotation
Ratio	1/1.7
Usage	Stationary
Output Torque	2433 lbf-ft

 This split shaft PTO guarantees the indicated values provided that it is used in suitable conditions and safety rules are abided by.

---

## Installation of Split Shaft PTO on the Vehicle

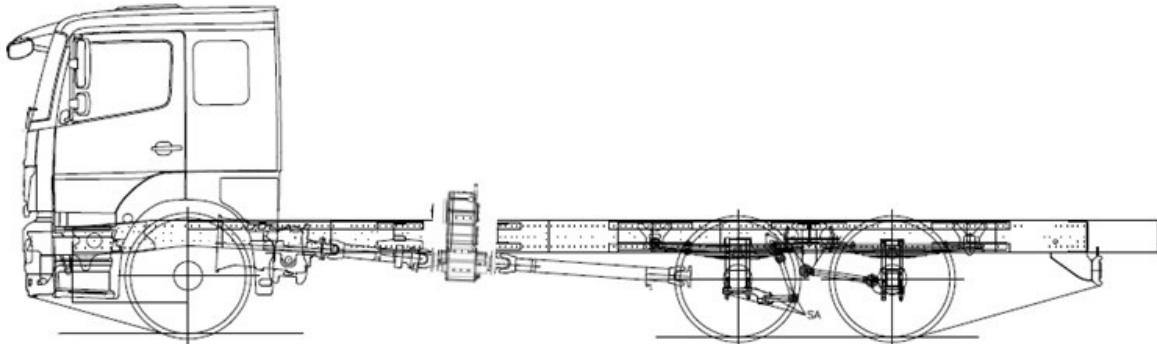

- ✓ Connect the SS PTO at an angle without disturbing the parallelism of the shaft as much as possible.
  - ✓ Use two sliding shafts: one in the input and the other on the output of the SS PTO.
  - ✓ Use two of the rubber pads on the right installation bracket and another two on the left when installing the SS PTO. Make sure that the direction of the pads are aligned with the model to be installed.
  - ✓ Do not mount any apparatus or equipment that will make it difficult to disassemble and assemble the SS PTO.
  - ✓ Since the SS PTO is controlled pneumatically, wait for the air to reach sufficient pressure before switching on.
  - ✓ There must be a special suspension kit for the SS PTO mounting installation.
  - ✓ SS PTO supports should be mounted with screws by drilling holes in the chassis at suitable places. Holes drilled on the chassis of the vehicle for SS PTO mounting must be made with the approval of the chassis manufacturer. Welding should never be used during the installation of the intermediate transmission on the vehicle chassis.
  - ✓ Care should be taken to ensure that the shafts to be used between the intermediate transmission and other components of the vehicle (main transmission, differential, etc.) are well-balanced.
-

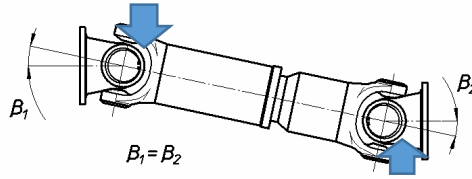

- ✓ U-connection flanges and the centers indicated by arrows must be parallel to each other in planar sense. Such a position would prevent vibration and noise. The transmission shaft must be mounted accordingly.  $B_1$  and  $B_2$  angles must be identical. These angles vary depending on the chassis and operating rpm, however they must be between  $3^\circ$  and  $7^\circ$  (Ensure that the shaft manufacturers have provided shaft connections complying with operating rpm-connection angle values). It must be borne in mind that connections with bigger shaft angle would cause.

 For longer operation of the SS PTO, use a conditioner in the pneumatic system.

## Engage and Disengage

The intermediate gearbox is switched on and off by means of a double-acting pneumatic cylinder (6-8 bar) and a safety system to maintain its fixed position. It is not necessary to supply air continuously during switching on and off. Air can be supplied momentarily and cut off after the system is switched on. This must only be done when the drive shaft is completely stopped. To completely stop the shaft movement, the clutch must be pressed and waited for at least 10 seconds.

## Activating the Top Outputs

When air is supplied to the system, the upper outputs are activated. When the upper outputs are activated, the differential output is deactivated. When the upper outputs are deactivated, the differential output is reactivated.

---

## Service and Maintenance

### Oil Filling

SS PTOs are shipped without oil. Oil must be added into them before commissioning through the oil filling mechanism. The task must be performed on a flat ground. Oil must be added by checking the oil level indicator provided on the equipment. The oil must be completely clean. You should only use the recommended oil types.

### Recommended Lubricants

75W90 Transmission Oil

80W90 Transmission Oil

Selection should be made according to the appropriate working conditions.

 **Oil capacity 372 oz**

 **Oil use other than the recommended oil types would put the equipment out of warranty coverage.**

 **Oil adding operation should be done by referring to the oil level indicator on the split shaft PTO.**

### Oil Level Inspection

Oil level should be inspected referring to the oil level indicator on the split shaft PTO. The equipment periodic maintenance should be performed weekly, and maintenance works should also be done after long operation hours. The maintenance must be performed on ground level and when the engine is off. Add oil if the oil levels are below the required limit.

---

## Oil Change

Make sure to drain the used oil completely before changing oil. It can be drained by opening the drainage cap. It is recommended to remove the filling cap to accelerate the process. The drainage cap must be cleaned before fastening it back. Care must be taken to have a new oil from the types recommended. Mixing old and new oil would result in shortening gearbox oil life.

## Oil Leakage Detection

Check for oil leakage periodically. Watch for oil leakage in vehicle operation site or surroundings. Upon detecting leakage, prevent it. After checking the available oil level, add oil into the equipment where necessary. Contact KOZANOGLU KOZMAKSAN if the oil leakage persists in spite of the intervention.



**Avoid contacting the hot oil during oil change for your occupational health. Remember to use your required personal protective equipment during split shaft PTO maintenance keeping in mind the occupational health safety requirements. Act in accordance with the applicable regulations considering environmental protection concerns while disposing the used oil.**

---



### Periodical Maintenance

Maintenance Period	Actions
First 300 hours or 2 Months	<ul style="list-style-type: none"> <li>✓ Regularly check the PTO for oil leakage.</li> <li>✓ After 300 hours or 2 month (whichever lapses first), change the oil.</li> </ul>
1000 Hours or 1 year	<ul style="list-style-type: none"> <li>✓ Regularly check the PTO for oil leakage.</li> <li>✓ After 1000 hours or 1 year (whichever lapses first), change the oil.</li> </ul>
5000 Hours or 2 Years	<ul style="list-style-type: none"> <li>✓ Regularly check the PTO for oil leakage.</li> <li>✓ After 5000 hours or 2 years, change the sealing components (O-ring, seal etc.).</li> </ul>
15000 Hours or 4 Years	<ul style="list-style-type: none"> <li>✓ Regularly check the PTO for oil leakage.</li> <li>✓ After 15000 hours or 4 years (whichever lapses first), change all bearings.</li> </ul>

 **Do not forget that this is a technical product, and change the replacement parts on time for its maintenance.**

---

**⚠ Check the components periodically. Inspect mounting components, transmission elements, drive and pump connection drive and pump connection shafts. If required, tighten them again.**

## Precautions for Emergency

If you wish to disengage the split shaft PTO in case of emergency, use the emergency stop mechanism provided by the manufacturer of the vehicle superstructure. This has to be done only by pressing the vehicle clutch pedal.

## Technical Drawings

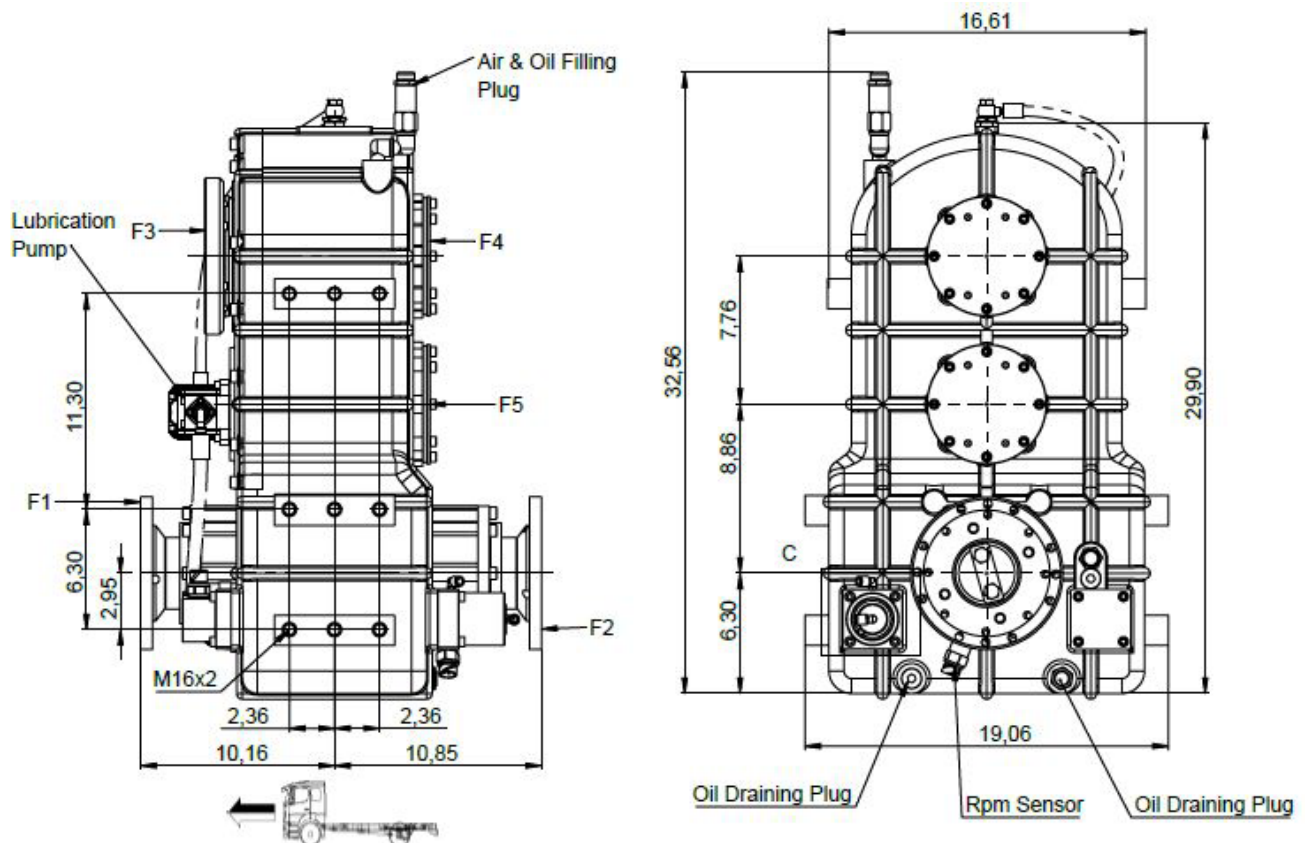

## Warranty Terms

1. Warranty period is one (1) year from the delivery of the product.
2. In the event that the product fails during the warranty period, the following apply:
  - Failure repair time is 1 to 8 working days depending on its nature,
  - Where the repair time lasts more than 7 working days (except transportation time), a new product shall be supplied to the customer till the failure has been repaired.
3. Where a failure occurs within the warranty period due to the defects possibly arising from the manufacturing stages, the product shall be repaired free of charge in terms of servicing and replaced part price.
4. Warranty certificate has to be presented when asking for services for the products under warranty. Where the certificate is lost or not resented, then sales invoice (invoice with waybill) has to be presented.

### Situations Which Terminate Warranty Obligations

The warranty obligations shall become null and void in following situation:

1. Using the product for a purpose other than the intended use,
  2. Changes to the product that are not approved by us,
  3. Digression from defined specifications and reference limits,
  4. Selling to third parties one or more products not bearing our approval seal
  5. Failing to perform indicated product maintenance,
  6. Having a service provider, other than the manufacturer or trader, repair, carry out maintenance works or replace parts of the product within the warranty period,
  7. Using the product against the usage terms set forth in the usage instructions,
  8. Where the product is damaged due to the mounting.
-